

## Search for Intracellular Sensors Involved in the Functioning of Monovalent Cations as Secondary Messengers

E. A. Klimanova<sup>1,a\*</sup>, S. V. Sidorenko<sup>1</sup>, A. M. Tverskoi<sup>1</sup>, A. A. Shiyan<sup>1</sup>, L. V. Smolyaninova<sup>1</sup>,  
L. V. Kapilevich<sup>2</sup>, S. V. Gusakova<sup>3</sup>, G. V. Maksimov<sup>1</sup>, O. D. Lopina<sup>1</sup>, and S. N. Orlov<sup>1,2,3</sup>

<sup>1</sup>Lomonosov Moscow State University, Department of Biology, 119234 Moscow, Russia

<sup>2</sup>National Research Tomsk State University, 634050 Tomsk, Russia

<sup>3</sup>Siberian State Medical University, Ministry of Health of Russian Federation, 634050 Tomsk, Russia

<sup>a</sup>e-mail: klimanova.ea@yandex.ru

Received June 3, 2019

Revised July 15, 2019

Accepted July 16, 2019

**Abstract**—Maintenance of non-equilibrium Na<sup>+</sup> and K<sup>+</sup> distribution between cytoplasm and extracellular medium suggests existence of sensors responding with conformational transitions to the changes of these monovalent cations' intracellular concentration. Molecular nature of monovalent cation sensors has been established in Na,K-ATPase, G-protein-coupled receptors, and heat shock proteins structural studies. Recently, it was found that changes in Na<sup>+</sup> and K<sup>+</sup> intracellular concentration are the key factors in the transcription and translation control, respectively. In this review, we summarize results of these studies and discuss physiological and pathophysiological significance of Na<sub>i</sub><sup>+</sup>,K<sub>i</sub><sup>+</sup>-dependent gene expression regulation mechanism.

DOI: 10.1134/S0006297919110063

**Keywords:** sodium, potassium, transcription, translation

In his works, Nobel prize winner Earl Wilbur Sutherland, Jr. has framed a concept, according to which any molecule could be considered as an intracellular signaling messenger if it satisfied following three major requirements. (i) Changes in this molecule intracellular concentration in response to the external stimuli occur prior to the generation of cell functional response, and this compound concentration remains the same after the stimulus ceases. (ii) In the absence of external stimuli,

**Abbreviations:** AMPK, AMP-activated protein kinase; CaMK, Ca<sup>2+</sup>/calmodulin-dependent protein kinase; COX-2, cyclooxygenase type 2; CREB, cyclic AMP response element-binding protein; CTS, cardiotonic steroids; EPS, electrical pulse stimulation; ERG, early response gene; GPCR, G-protein-coupled receptor; HIF-1, hypoxia-inducible factor 1; HRE, HIF-response element; HSP, heat shock protein; NaRE, identified Na<sup>+</sup> response element, gene transcription regulator; NaREB, unidentified [Na<sup>+</sup>]<sub>i</sub> sensor, NaRE activator; NBD, nucleotide-binding domain; NFAT, nuclear factor of activated T cells; NFκB, nuclear factor kappa-light chain enhancer of activated B cells; NMDA, *N*-methyl-D-aspartate; SBD, substrate-binding domain; SERCA, skeletal muscle sarcoplasmic/endoplasmic-reticulum Ca-ATPase; SMC, smooth muscle cell; UTR, untranslated mRNA region.

\* To whom correspondence should be addressed.

changes in the messenger intracellular concentration are sufficient for the generation of cell response. (iii) Cell functional response is mediated by interaction between the messenger and its highly selective intracellular sensors [1]. Further works demonstrated that low-molecular-weight compounds, such as cyclic nucleotides (cAMP, cGMP), products of phospholipid catabolism (diacylglycerol, inositol-1,4,5-triphosphate), and Ca<sup>2+</sup> ions, meet these requirements [2-5].

Similar to above mentioned canonic messengers, monovalent ions intracellular concentrations change temporarily in response to various stimuli. For example, Na<sub>ex</sub><sup>+</sup>/H<sub>i</sub><sup>+</sup> exchange activation by growth factors and subsequent [Na<sup>+</sup>]<sub>i</sub> increase have been observed in all investigated cell types [6-11]. Activation of Ca<sup>2+</sup>-dependent K<sup>+</sup> channels in mammalian erythrocytes with membrane potential close to chloride equilibrium potential [E<sub>m</sub> = E<sub>Cl</sub> ~ -(8-12) mV] resulted in 5- to 8-fold [K<sup>+</sup>]<sub>i</sub> decrease [12], which, in turn, was accompanied by cell shrinkage and eryptosis – special form of erythrocyte programmed death [13]. Short-term synaptic activity in neurons and astrocytes resulted in local [Na<sup>+</sup>]<sub>i</sub> increase from ~10 to 50-100 mM, which can be explained by Na<sup>+</sup> influx through ionotropic glutamate receptors or Na<sub>ex</sub><sup>+</sup>-coupled

neuromediator transporters [14, 15]. Hypoxia of smooth muscle cells (SMCs) resulted in 2- to 3-fold  $[\text{Na}^+]_i$  increase, which together with hypoxia-induced transcription factor 1 (HIF-1) expression upregulation causes changes in gene expression profile [16, 17]. Extensive exercise was found to trigger dissipation of  $\text{Na}^+$  and  $\text{K}^+$  transmembrane gradients in skeletal muscles, leading to 5- to 10-fold  $[\text{Na}^+]_i/[\text{K}^+]_i$  ratio increase [18]. These data, as well as the results of studies on  $\text{Na}^+$ ,  $\text{K}^+$ ,  $\text{Cl}^-$ , and  $\text{HCO}_3^-$  selective effects on the enzyme activity and gene expression, allowed Orlov and Hamet [19] to formulate a hypothesis that proposed monovalent ions as secondary messengers. Purpose of this review is to summarize new studies data on this topic with special emphasis on identification of monovalent cation intracellular sensors. Data on monovalent anions involvement in intracellular signaling has been reviewed in recent publications [20, 21].

### IDENTIFIED SENSORS OF MONOVALENT CATIONS

The most studied membrane transporters, which activity is controlled by  $\text{Na}^+$  and/or  $\text{K}^+$  ions in the concentrations comparable to their intracellular quantity (the first indication that these proteins might contain highly specific binding sites of these cations), are shown in Fig. 1. Other proteins exhibiting activity changes in response to monovalent cation concentration alteration have been also identified [22, 23]. In this section of our review, we summarize data of monovalent cation-binding sites structural studies.

**Na,K-ATPase.** Although the first  $\text{Na}^+$  and  $\text{K}^+$  selective transporters were identified 70 years ago, structure of these cations binding sites has been investigated in detail only for Na,K-ATPase.

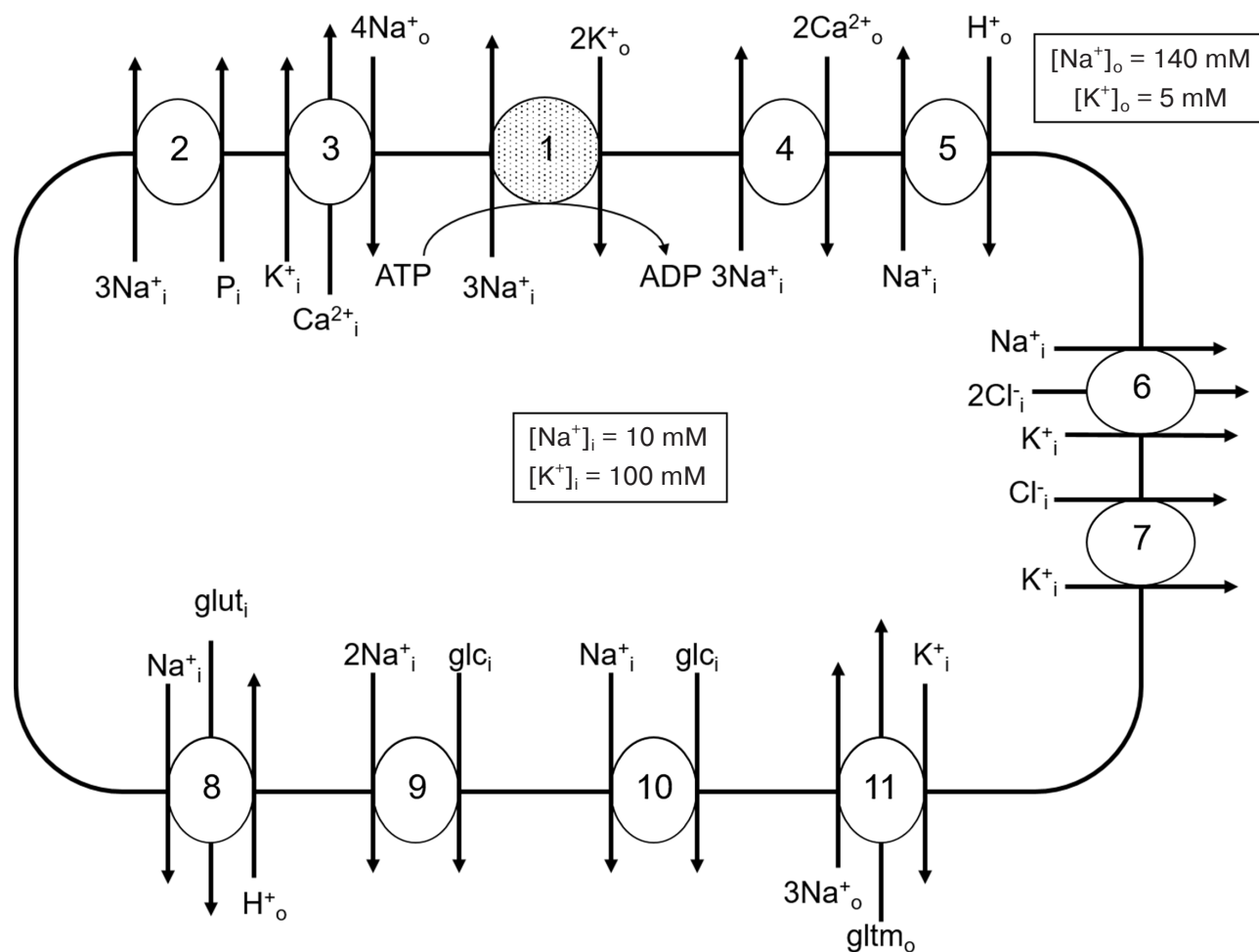

**Fig. 1.** Membrane transporters whose activity is controlled by intracellular sodium (1, 2, 4-6, 8-10) and potassium (3, 6, 7, 11): 1) Na,K-ATPase; 2)  $3\text{Na}^+$ , phosphate cotransporter; 3)  $\text{K}^+$ -dependent  $4\text{Na}^+/\text{Ca}^{2+}$  exchanger (KNCX); 4)  $3\text{Na}^+/\text{Ca}^{2+}$  exchanger (NCX); 5)  $\text{Na}^+/\text{H}^+$  exchanger; 6)  $\text{Na}^+, \text{K}^+, 2\text{Cl}^-$  cotransporter (NKCC); 7)  $\text{K}^+, \text{Cl}^-$  cotransporter (KCC); 8)  $\text{H}^+$ -dependent  $\text{Na}^+$ , glutamine cotransporter (SNAT3); 9)  $2\text{Na}^+$ , glucose cotransporter (SLC5A1); 10)  $\text{Na}^+$ , glucose cotransporter (SLC5A2); 11)  $\text{K}^+$ -dependent  $3\text{Na}^+$ , glutamate cotransporter. Shown only ion transport directions activated by the increase in  $\text{Na}^+$  and  $\text{K}^+$  intracellular concentrations. Values of sodium and potassium concentrations in extracellular fluids and cytoplasm of resting cells are shown on the example of blood plasma and human erythrocytes.

During its catalytic cycle, Na,K-ATPase exists alternatively in two conformational states; one of them displays high affinity for Na<sup>+</sup> ions (E1) and the other – for K<sup>+</sup> ions (E2). These two conformations' spatial structure comparison made it possible to decipher the enzyme cation-binding structure (Fig. 2). According to conformation E1 X-ray diffraction data [24], three Na<sup>+</sup>-binding sites (I, II, and III) are located within the transmembrane part of the  $\alpha$ -subunit (between transmembrane  $\alpha$ -helices M4, M5, M6, and M8) at  $\sim 1/3$  depth of membrane thickness from the cytoplasmic surface. Ala323, Glu779, Asp804, Asp808, Thr772, Ser775, Asn776 (site I); Val322, Ala323, Val325, Glu327, Asp804 (site II); and Tyr771, Thr772, Thr774, Ser775, Asp808, Gln923, Asp926 (site III) are the main amino acid residues of enzyme  $\alpha$ -subunit that are involved in Na<sup>+</sup>-binding sites development. Site I is located at the same position as one of the K<sup>+</sup>-binding sites, while site II is 5 Å closer to the membrane cytoplasmic surface. Both sites I and II are situated in vicinity of the cytoplasmic part of the M5 transmembrane helix and separated by the Ser775 side chain. Site III is sterically limited (along M5) and too small to accommodate K<sup>+</sup> ion.

Distance between I and II Na<sup>+</sup>-binding sites is 3.2–3.6 Å, which is less than the distance between the two K<sup>+</sup>-binding sites. It is likely sufficient for adjacent positioning of two sodium ions, but not for two potassium ions (ionic radii, 0.95 and 1.33 Å, respectively). It was suggested that these sites selectively bind Na<sup>+</sup>, because the cavity with 2.4 Å radius would be sufficient for Na<sup>+</sup> binding, while K<sup>+</sup> binding requires 2.8 Å radius cavity. Precisely this size

cavity was found in Na,K-ATPase E2 conformation crystal (i.e., conformation with high K<sup>+</sup> affinity). Site I is the least sterically limited; hence, it likely acts as the K<sup>+</sup>-binding site, because Ser775 and Asn776 side chains participate in the coordination of both Na<sup>+</sup> and K<sup>+</sup> ions. Sites II and III in the E1 conformation are not sufficiently large for K<sup>+</sup> binding. However, it is possible that site II cavity enlarges during E1 to E2 transition, so this site becomes capable of K<sup>+</sup> binding.

The following scenario is possible to explain sequential and cooperative binding of three Na<sup>+</sup> ions: E1 conformation cavity size is sufficient for accepting the first cytoplasmic Na<sup>+</sup> ion (but not K<sup>+</sup> ion) in the site III only if Ser775 side chain shifts its position. Based on X-ray diffraction analysis data, it can be assumed that the first Na<sup>+</sup> ion is transported to the site III and binds to it, but the sites I and II should not be completely formed at the moment of Na<sup>+</sup> transport (otherwise Na<sup>+</sup> would bind to them). Only after the first Na<sup>+</sup> ion binds to site III and the second Na<sup>+</sup> ion to the site I, the binding site II is formed.

It is known that Ca<sup>2+</sup>-binding sites in another P-type ATPase, specifically skeletal-muscle sarcoplasmic-reticulum/endoplasmic-reticulum Ca-ATPase (SERCA), are formed mostly by the same amino acid residues as in Na,K-ATPase [25]. Transmembrane M5 helix cytoplasmic portion orientation plays an important role in Na,K-ATPase selectivity toward Na<sup>+</sup>. According to the X-ray diffraction data, straightening of M5 helix (as in Ca-ATPase) makes K<sup>+</sup> binding in the site III possible. Indeed, removal of C-terminal amino acid residues in Na,K-ATPase  $\alpha$ -subunit increases M5 helix mobility and

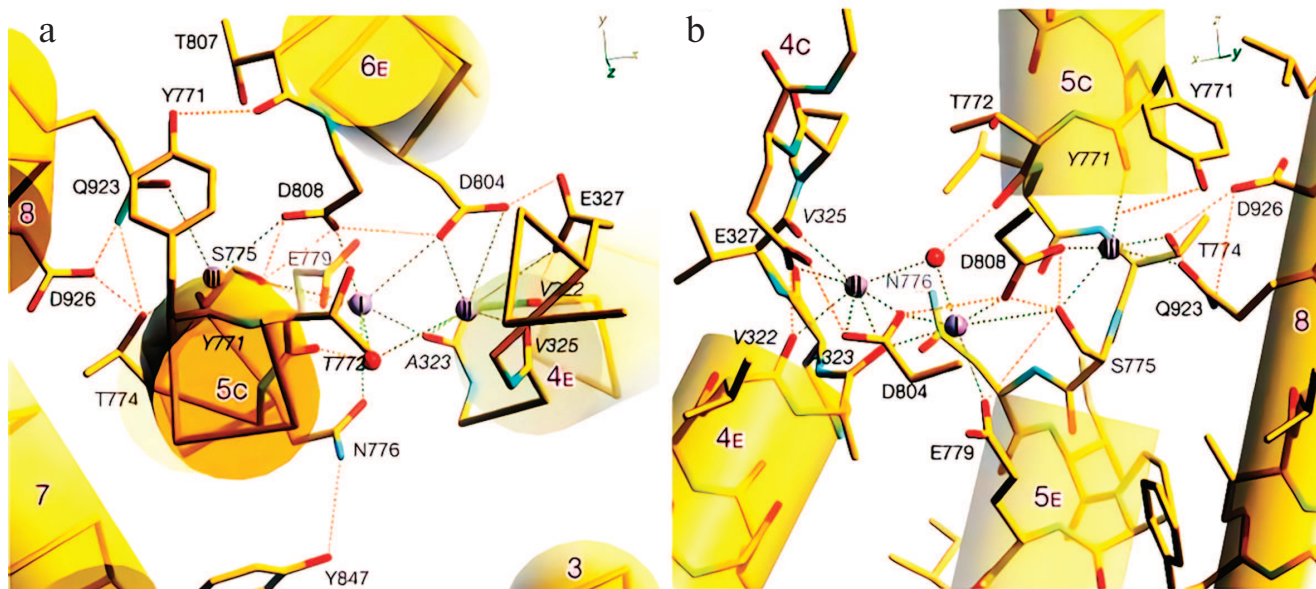

**Fig. 2.** Na,K-ATPase Na<sup>+</sup>-binding sites atomic model is presented in orientation (a) perpendicular to the membrane (view from the cytoplasmic side) and (b) parallel to the membrane (view from the M6 helix side). Amino acid residues shown in italic indicate that the carbonyl groups of the main chain facilitate Na<sup>+</sup> coordination. Green dashed lines, possible coordination of Na<sup>+</sup>; orange lines, potential hydrogen bonds (provided that carboxyl groups are protonated) (data from Kanai et al. [24]).

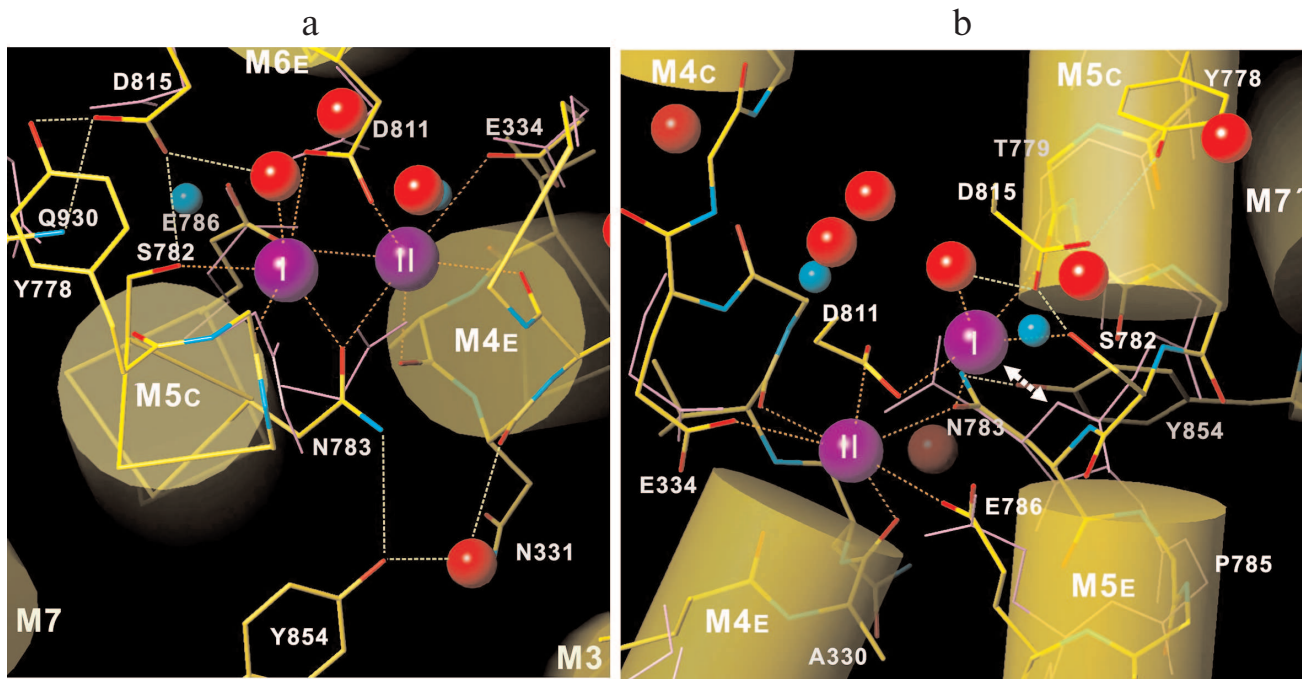

**Fig. 3.** Na,K-ATPase  $K^+$ -binding sites atomic model shown (a) from the cytoplasmic side along the M5-helix and (b) parallel to the membrane. Solid purple lines denote side and main chains of SERCA  $Ca^{2+}$ -coordinating amino acid residues. Purple spheres,  $K^+$  ions; red spheres, water molecules; blue spheres,  $Ca^{2+}$  ions bound to SERCA. Double arrow in panel (b) depicts steric collision between  $K^+$ -binding site I and Asn783 amide in SERCA (Na,K-ATPase Asn783 analogue) (data from Toyshima et al. [26]).

results in decrease of  $Na^+$  enzyme affinity and  $K^+$  binding in the site III.

Na,K-ATPase belongs to the P-type ATPase family, whose members display significant homology in the amino acid sequences and similarity in catalytic subunit three-dimensional structure, as well as in ATP hydrolysis and ion transport mechanisms. This was the reason for Toyoshima et al. [26] to discuss in detail why Na,K-ATPase is capable of  $K^+$  and some other monovalent cations binding, while SERCA can bind  $H^+$  in addition to  $Ca^{2+}$ . Based on data from Na,K-ATPase E2 conformation X-ray diffraction analysis with 2.4 Å resolution, the following conclusions can be made. First, unlike  $Ca^{2+}$ -binding sites in SERCA,  $K^+$ -binding sites are located at extremely close distances from each other, despite the fact that  $K^+$  ionic radius is much bigger than that of  $Ca^{2+}$  (1.353 and 0.99 Å, respectively) (Fig. 3). It was suggested that such close positioning is possible only for monovalent cation-binding sites, because in this case, oxygen atoms of carbonyl groups in the polypeptide chain coordinate cations in both enzymes. Second, enzyme structure comparison revealed that coordination geometry of bound cations differs significantly in Na,K-ATPase and SERCA, which suggests potentially low ion-binding sites affinity of SERCA to monovalent cations. Moreover, calculated  $Na^+$  and  $K^+$  valence values are slightly different, thus suggesting that these binding sites are not very  $K^+$

selective. Altogether, these data support the idea that Na,K-ATPase primary function is  $Na^+$  pumping. Third, amino acid side chains' location and conformation in Na,K-ATPase are very similar to those in SERCA  $Ca^{2+}$ -binding sites with the Asn783 exception. In Na,K-ATPase, this amino acid residue forms hydrogen bond with Tyr854 in M7 helix kink; M5 helix is also partially unfolded forming a kink due to Pro785 presence, which plays a crucial role in space and  $K^+$  coordination creation by interacting with Thr799 backbone carbonyl oxygen. In SERCA, Pro785 is replaced with Gly770, which results in less M5 helix bending and, respectively, smaller size of empty cavity. As a result, SERCA Asn783 amide (Na,K-ATPase Asn783 analogue) is very close to the first  $K^+$ -binding site and to site II side chain, which prevents  $K^+$  binding to these SERCA sites. All these findings demonstrate that although formation of monovalent cation binding sites involves similar amino acid residues, sites emerge as a result of protein three-dimensional structure formation, and even slight alterations in the protein spatial structure significantly affect cation-binding sites' structure.

**G-protein-coupled receptors.** G-protein-coupled receptors (GPCRs) is the largest membrane proteins superfamily representing one third of all pharmacological targets. GPCRs found in the human genome (826 in total) are subdivided into four families (A, B, C, and F)

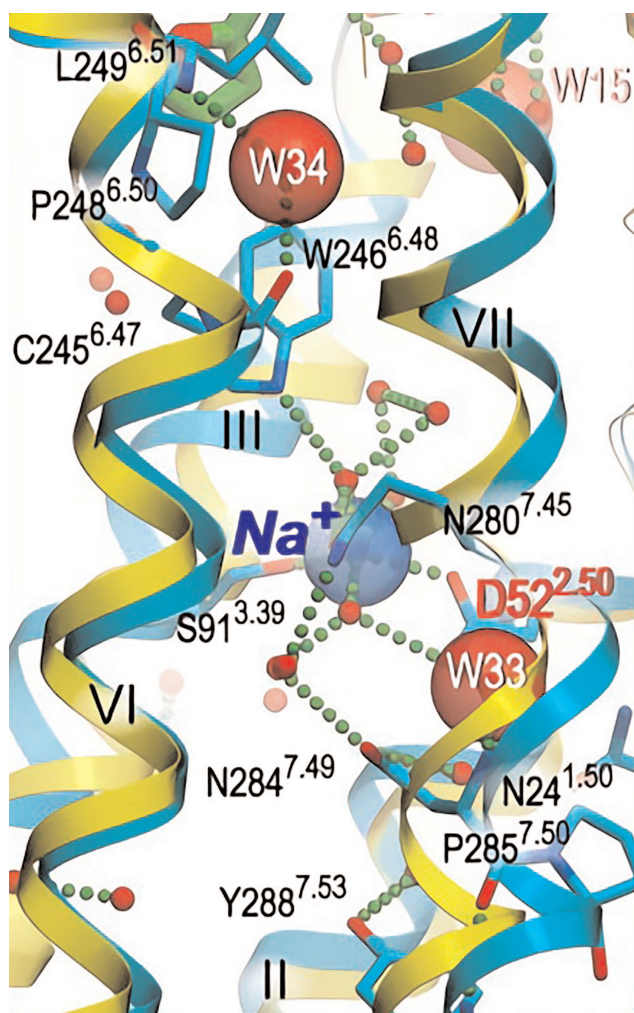

**Fig. 4.** GPCR transmembrane domain central cluster composed of seven helices (marked with Roman numerals) in antagonist-bound (cyan) and agonist-bound (yellow) states. Red spheres, water molecules; green dotted lines, salt bridges and hydrogen bonds; transparent blue sphere,  $\text{Na}^+$  ion; red semitransparent spheres, water molecules W33 and W34 that stabilize kinks in helices VI and VII (data from Liu et al. [30]).

varying in the amino acid sequences. In the middle of 1970s, Pert et al. [27] discovered that  $[\text{Na}^+]_i$  increase within 10–100 mM in brain homogenates decreased agonists binding to the family A opioid receptors without pronounced antagonist binding effect. Later, the same phenomenon was observed for adrenergic receptors, as well as adenosine, dopamine, bradykinin, and other GPCRs [28, 29]. GPCR mutants studies revealed that  $\text{Na}^+$ -dependent regulation of the receptor requires aspartic acid presence in the second transmembrane GPCR domain. Together with high-resolution crystallography, these studies have established highly conservative  $\text{Na}^+$ -binding site structure located in central cluster transmembrane domain composed of seven helices (Fig. 4). This cluster is a part of the water-filled channel located

between ligand-binding and G-protein-binding sites. This channel has two narrow “necks” where its diameter decreases to the size slightly smaller than water molecule diameter (2.4 and 2.0 Å) due to the Trp246 and Tyr288 residue presence, respectively. Ligand binding changes receptor conformation, which results in the channel closing at these sites.

Central part of the channel between Trp246 and Tyr288 (located 13 Å from each other) is completely filled with  $\text{Na}^+$  ion and 10 water molecules.  $\text{Na}^+$  is coordinated by Asp52 and Ser91 five oxygen atoms and three water molecules. In addition,  $\text{Na}^+$  forms hydrogen bonds with highly conserved amino acids Asn24, Trp246, Asn280, Asn284, and Tyr288 [30].

Considering that  $\text{Na}^+$  can enter central cluster from both sides of the membrane, the question arises whether it is extracellular or intracellular  $\text{Na}^+$  that controls the receptor activity.  $\text{Na}^+$  allosteric effect on ligand binding is a well-known fact reported in numerous studies. However, in the majority of investigated GPCRs,  $\text{Na}^+$  inhibits agonist binding with  $\text{IC}_{50} \sim 50$  mM [29, 31, 32]. Based on these observations, as well as  $[\text{Na}^+]_{\text{ex}}$  value of 140 mM, extracellular  $\text{Na}^+$  involvement in GPCR activity regulation seems unlikely. The issue of intracellular  $\text{Na}^+$  contribution to GPCR functioning remains unsolved.

**Heat shock proteins.** Heat shock proteins with 70-kDa molecular mass (Hsp70) are conservative in almost all living organisms, where they are involved in numerous intracellular regulation processes, including folding of newly synthesized and/or denatured proteins to prevent their aggregation. Hsp70 family members display ATP-dependent chaperon activity. It was established that Hsp70 ATPase activity increases sharply in response to  $\text{K}^+$  concentration increase within 20–100 mM range, while  $\text{Na}^+$ ,  $\text{Li}^+$ , and  $\text{Cs}^+$  produce almost no effect on the ATPase activity [33].

Hsp70 consists of *N*-terminal nucleotide-binding domain (NBD) and *C*-terminal substrate-binding domain (SBD). Hsp70 NBD in a complex with ADP crystal structure data from *Escherichia coli* revealed that this domain contains  $\text{K}^+$ -binding site. When bound,  $\text{K}^+$  ion is coordinated by ADP  $\beta$ -phosphate group, Asp10 side chain, and Tyr15 main chain (Fig. 5). When  $\text{K}^+$  is replaced by  $\text{Na}^+$ , the latter is also coordinated by ADP, Asp10, Tyr15 and located at the same position as  $\text{K}^+$  [34].

Above data demonstrate fundamental difference in monovalent ions and  $\text{Ca}^{2+}$ -binding sites structural organization. Indeed,  $\text{Ca}^{2+}$ -binding sites in parvalbumin, calmodulin, troponin C, and a number of other proteins contain so-called EF-hand motif composed of 14-a.a. sequence [35, 36]. Examples given above show that monovalent cation binding sites are formed by amino acid residues located far apart from each other in the polypeptide chain with their geometry controlled by protein three-dimensional structure. This feature does not

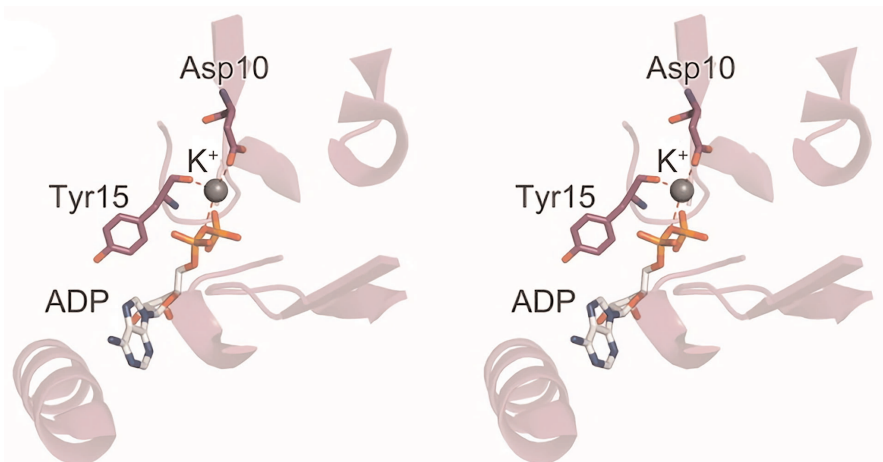

**Fig. 5.** Interaction between Hsp70 nucleotide-binding domain (NBD) from *E. coli* and ADP in the absence of  $Mg^{2+}$  ion. Grey sphere,  $K^+$  ion; red dashed lines, coordination bonds (data from Arakawa et al. [34]).

allow direct scanning of cDNA libraries for potential  $Na^+$  and  $K^+$  sensors, the strategy that has been successfully employed for  $Ca^{2+}$ -binding proteins identification [37]. It must also be mentioned that unlike proteins with EF-hand motif and saturated at  $\sim 1 \mu M$   $Ca^{2+}$  concentrations, monovalent cation binding sites affinity changes from 10 to 100 mM, which makes it challenging to use radioactive isotopes for protein identification in cell lysates.

#### SODIUM AS A TRANSCRIPTION REGULATOR

Cell shrinking and swelling are considered as universal markers of two different types of cell death – apoptosis and necrosis, respectively [38, 39]. In order to elucidate apoptosis mechanism, we compared effects of ion transport inhibitors on cell volume and viability. To our surprise, we discovered that prolonged rat aorta SMCs incubation with ouabain or in  $K^+$ -free incubation medium (both inhibit Na,K-ATPase) attenuated apoptosis that has been induced by the lack of growth factors [40]. Na,K-ATPase inhibitors' antiapoptotic effect was also demonstrated in renal epithelial proximal tubular cells culture [41], brain neurons [42], and vascular endothelial cells [43]. In further experiments we also found that SMCs Na,K-ATPase inhibition causes sharp activation of RNA synthesis [44] and generation of large amounts of newly synthesized proteins [45–47], which suggested expression of early response genes (ERGs). Indeed, cell treatment with ouabain resulted in significant *c-Fos* and *c-Jun* overexpression, the most studied ERG family representatives [47]. Taking into account that apoptosis prevention by Na,K-ATPase inhibitors was abolished by RNA (actinomycin D) and protein

(cycloheximide) synthesis inhibitors [48], we suggested that this effect was mediated by transcription and/or translation regulation.

Data obtained during last 20 years have shown that ouabain and other cardiotonic steroids (CTSs) can generate intracellular signals independently from Na,K-ATPase inhibition [49, 50]. Considering this fact, we used Affymetrix technology and compared the effects of ouabain and potassium-depleted medium (as two independent methods for Na,K-ATPase inhibition) on SMCs, human umbilical vein endothelial cells (HUVECs), and HeLa cells transcriptomes [51]. Ouabain or the lack of  $K^+$  (Na,K-ATPase activator) altered expression of >500 genes with highly reliable positive correlation, which suggested dissipation of ion gradients and increase in  $[Na^+]_i/[K^+]_i$  ratio as the main mechanisms of transcription regulation. It was established that 80 of the  $Na^+_i/K^+_i$ -dependent gene transcripts were common for all three types of cells [51], as well as for rat brain neurons and mouse myoblast C2C12 cells [52]. Many ERGs, including *Fos*, *FosB*, *Jun*, *JunB*, *Atf3*, and *Egr-1*, were among these common  $Na^+_i/K^+_i$ -dependent genes.

We have established in primary experiments that ouabain protected cells from apoptosis in medium with elevated  $K^+$  content, this effect disappeared with  $Na^+$  transmembrane gradient dissipation [40, 53]. This indicates that ouabain antiapoptotic effect is due to  $Na^+_i$  increase rather than to  $K^+_i$  depletion. Conclusion on the leading role of  $Na^+_i$  increase is in agreement with the data comparing the kinetics of ouabain effects on ERG expression and  $Na^+_i$  and  $K^+_i$  content in SMCs [47]. Indeed, 4-fold decrease in *c-Fos* mRNA content was observed 30 min after ouabain addition, when intracellular  $Na^+$  content increased 5-fold, but  $K^+_i$  content decreased only by 10–15% (Fig. 6).

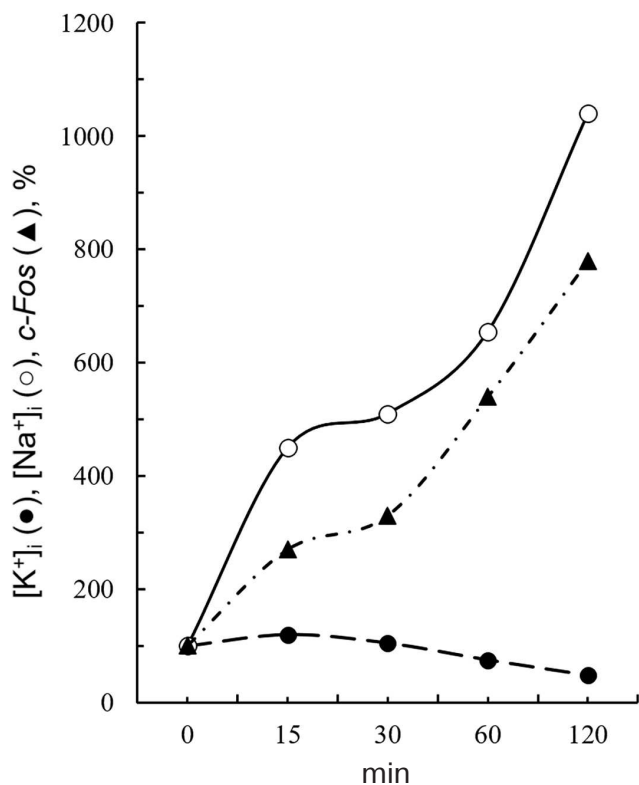

**Fig. 6.** Time course of the intracellular potassium content ( $[K^+]_i$ ), sodium content ( $[Na^+]_i$ ), and *c-Fos* mRNA in the aorta SMCs in response to 1 mM ouabain addition (data from Taurin et al. [47]).

**Proof of  $Ca^{2+}$ -independent signaling.** Numerous studies have revealed that an increase in intracellular calcium concentration ( $[Ca^{2+}]_i$ ) is accompanied by activation of several signaling systems involved in so-called excitation-transcription coupling [54-57]. First,  $[Ca^{2+}]_i$  increase results in  $Ca^{2+}$ /calmodulin-dependent protein kinase (CaMK) isoforms activation, I $\kappa$ B inhibitor phosphorylation, and NF $\kappa$ B (nuclear factor kappa-light-chain enhancer of activated B cells) translocation from the cytoplasm to the nucleus after phospho-I $\kappa$ B release. Second,  $[Ca^{2+}]_i$  increase is accompanied by nuclear factor of activated T cells (NFAT) dephosphorylation by  $Ca^{2+}$ /calmodulin-dependent phosphatase calcineurin and translocation of the former to the nucleus. Third, an increase in  $[Ca^{2+}]_i$  leads to transcription regulator CREB (cyclic AMP response element-binding protein) phosphorylation. NF $\kappa$ B, NFAT, and CREB translocated into the nucleus interact with the corresponding binding sites in the 5'-untranslated regions (5'-UTRs) in gene promoters.

In some cell types, prolonged Na,K-ATPase inhibition is accompanied by  $[Ca^{2+}]_i$  increase due to the activation of  $Na^+$ / $Ca^{2+}$  exchange and/or membrane depolarization followed by  $Ca^{2+}$  influx through the voltage-gated  $Ca^{2+}$  channels. In particular, we have shown that ouabain

causes activation of  $Na^+$ / $Ca^{2+}$  exchange in human lung fibroblasts [58] and of voltage-gated L-type  $Ca$ -channels in rat aorta SMCs [59]. It could be suggested that transcriptome changes in response to  $[Na^+]_i/[K^+]_i$  ratio increase are associated with  $[Ca^{2+}]_i$  increase and activation of above mentioned  $Ca^{2+}$ -dependent transcription regulation mechanisms. This hypothesis, however, contradicts the data obtained with calcium chelators. Indeed, extracellular and intracellular  $Ca^{2+}$  chelators (EGTA and BAPTA-AM, respectively) did not affect ouabain-induced *c-Fos* upregulation in SMCs [47]. Moreover, loading cells with calcium chelators increased rather than decreased number of genes whose expression was altered in response to Na,K-ATPase inhibition [51]. Among universal  $Na^+$ / $K^+$ -dependent genes, whose expressed changed more than 3-fold in the presence of  $Ca^{2+}$  chelators in all investigated cell types, were identified transcription factors (*Fos*, *Jun*, *Hes1*, *Nfkb1a*), interleukin-6 (*Il-6*), and cyclooxygenase type 2 (*COX-2* or *Ptgs2*).

While analyzing this data it should be kept in mind that calcium chelators can affect cell functions independently from calcium depletion. In particular, we observed that EGTA addition to SMCs caused an increase in sarcolemma permeability for monovalent cations [60] and ~10-fold  $[Na^+]_i/[K^+]_i$  ratio increase [59]. It is then not surprising that the content of 2071 transcripts was altered with high reliability in response to Na,K-ATPase inhibition ( $R^2 > 0.51$ ;  $p < 10^{-12}$ ) and addition of  $Ca^{2+}$  chelators [61]. Beside changing plasma membrane permeability,  $Ca^{2+}$  chelators can affect gene transcription via binding polyvalent cations, because EGTA and BAPTA affinity to  $Mn^{2+}$ ,  $Zn^{2+}$ ,  $Cu^{2+}$ ,  $Co^{2+}$ , and  $Fe^{2+/3+}$  is several orders of magnitude higher than to  $Ca^{2+}$ . This is the reason why calcium ions chelation is accompanied by changes in number of proteins (including numerous transcription regulation factors containing  $Zn^{2+}$ -binding domains) regulated by polyvalent cations activity [62]. In 1981, Krishtal et al. [63] reported a sharp increase in calcium channel conductance in the presence of  $Ca^{2+}$  chelators, which also indirectly indicated  $Ca^{2+}$  chelators influence on cell metabolism.

While searching for alternative approaches to study  $Na^+$ -sensitive gene transcription regulation mechanisms, we used  $Ca^{2+}$ -dependent signaling systems inhibitors. We found that increase in *Egr1* and *Atf3* expression in ouabain-treated SMCs was independent from the presence of voltage-gated  $Ca^{2+}$  channels and  $Na^+$ / $Ca^{2+}$  exchange inhibitors, as well from calmodulin antagonists and  $Ca^{2+}$ /calmodulin-dependent protein kinases and phosphatases inhibitors. At the same time, *Ptgs2* and *Nr4a1* expression upregulation was attenuated in the presence of  $Ca^{2+}$ -dependent protein kinase (CaMKII) and calcineurin inhibitors, respectively (Fig. 7) [59]. All data presented in this section indicate  $Ca^{2+}$ -independent mechanisms involvement in the transcriptional regulation of genes, whose expression is altered by Na,K-

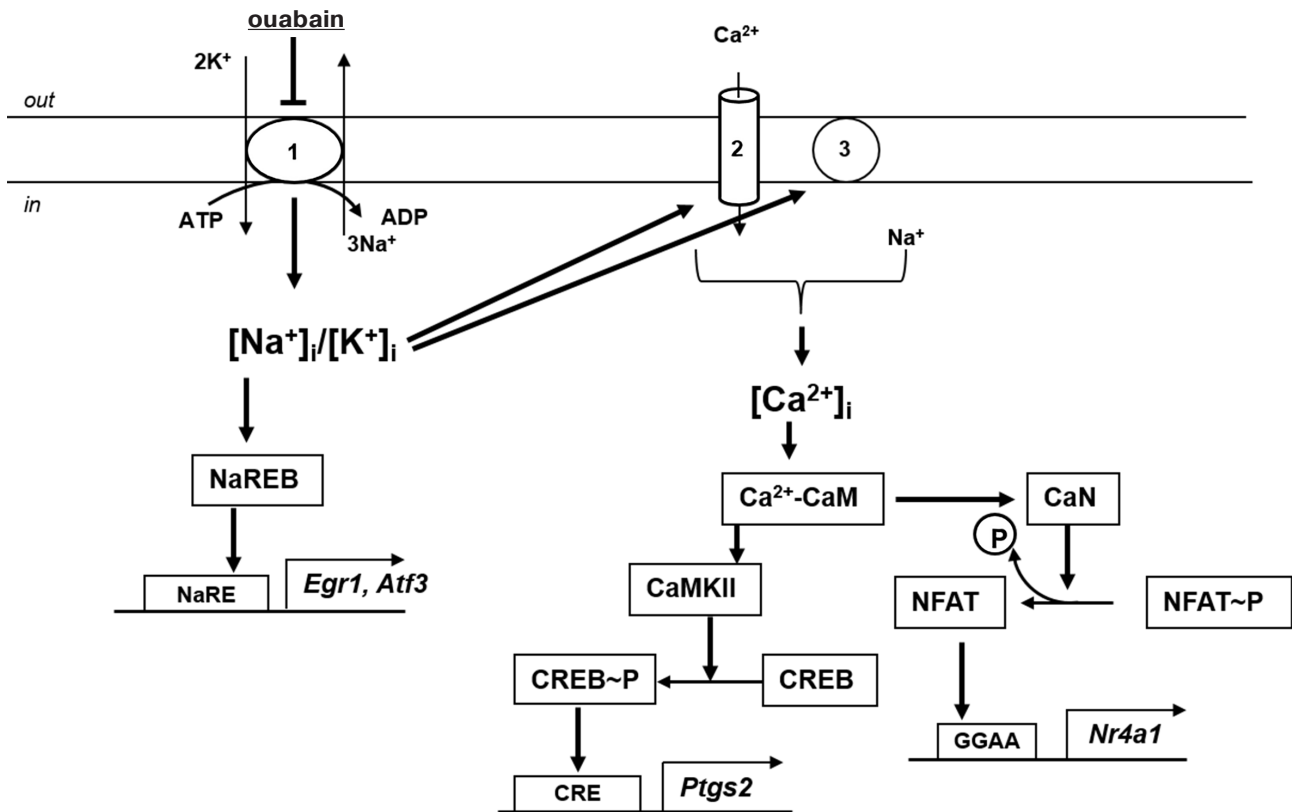

**Fig. 7.** Involvement of monovalent cations and  $\text{Ca}^{2+}$  in the regulation of *Egr1*, *Atf3*, *Ptgs2*, and *Nr4a1* transcription in rat aorta SMCs: 1) Na,K-ATPase; 2) voltage-gated  $\text{Ca}^{2+}$  channels; 3)  $\text{Na}^+/\text{Ca}^{2+}$  exchanger; CaM, calmodulin; CaN, calcineurin; NaRE, identified  $\text{Na}^+$ -dependent element regulating gene transcription; NaREB, non-identified sensor of  $[\text{Na}^+]_i$  changes activating NaRE.

ATPase and other stimuli causing an increase in  $[\text{Na}^+]_i$  inhibition.

**Canonical 5'-UTR promoters are not involved in the transcriptional regulation of  $\text{Na}^+$ -dependent genes.** Mechanism of gene expression regulation mediated by interaction of ERG products and other transcription factors regulators with binding sites located in untranslated 5'-UTR sequence has been studied most comprehensively. Based on this fact, we have attempted to identify  $\text{Na}^+$ -dependent transcription regulation element ( $\text{Na}^+$  response element, NaRE) in  $\text{Na}^+$ -dependent gene *c-Fos* 5'-UTR sequence. This approach was justified by the absence of ouabain effect on the level of human *c-Fos* mRNA in NIH 3T3 mouse fibroblasts transfected with *c-Fos* gene with removed (–222)–(–70) sequence in the 5'-UTR [64]. Given the results of these studies HeLa cells were transfected with luciferase gene under control of 5'-UTR *c-Fos* long section ending at nucleotide (–650). This DNA fragment contained all studied promoter elements activated by growth factors and other canonical transcription regulators (Fig. 8). Cells treated with growth factors contained in the serum were used as a positive control. Similar to SMCs [47], Na,K-ATPase inhibition in HeLa cells with either ouabain or potassium-depleted

medium was accompanied by *c-Fos* expression upregulation (Fig. 8a). However, contrary to the endogenous *c-Fos*, luciferase expression was not regulated by ouabain, but instead was activated by addition of serum growth factors (Fig. 8b) [65]. These results indicated that increase in *c-Fos* mRNA content in response to Na,K-ATPase inhibition was not mediated by 5'-UTR site interaction with classic transcription regulators. Other  $\text{Ca}^{2+}$ -independent regulation mechanisms of the  $\text{Na}^+$ -dependent transcriptome are discussed in the following section of this review.

**Search for sensors involved in the transcription regulation of  $\text{Na}^+$ -dependent genes.** Negative results presented above can be explained by the existence of the following alternative mechanisms. (i)  $\text{Na}^+$  interacts with  $\text{Ca}^{2+}$ -binding sites of calpain at relatively low  $[\text{Ca}^{2+}]_i$  (~100 nM) causing half-maximum enzyme activation at  $[\text{Na}^+]_i = 15$  mM [66]. Role of  $\text{Ca}^{2+}$ -binding proteins in transcription regulation via interaction with monovalent cations remains poorly understood. (ii) 5'-UTR site responsible for  $\text{Na}^+$ -mediated *c-Fos* transcription regulation is located far from the canonical promoter. In fact, it was established that chromatin reorganization affects *c-Fos* through 5'-UTR adjacent nucleotide (–1900) [67]. Farther located tissue-specific alternative promoters have



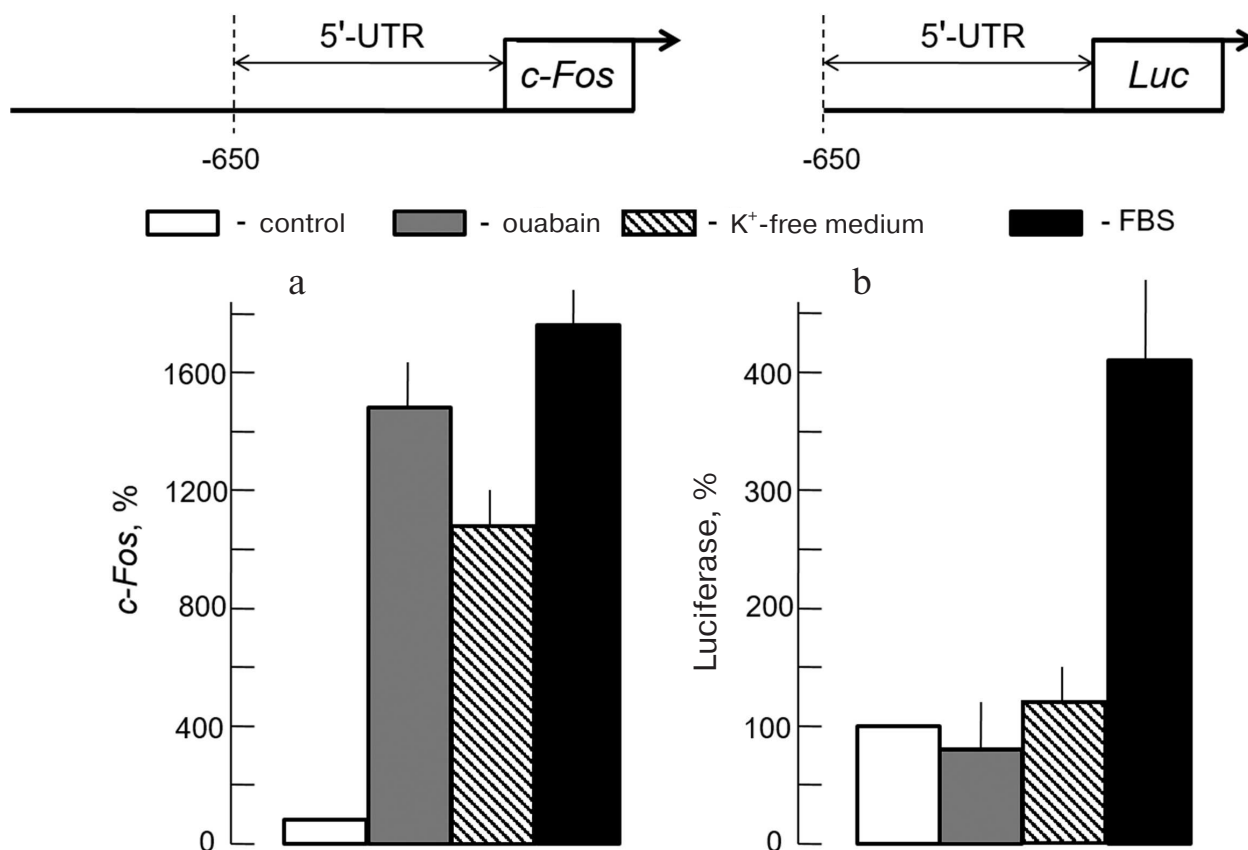

**Fig. 8.** Changes of endogenous *c-Fos* mRNA content (a) and luciferase expression under 5'-UTR *c-Fos* control (b) in HeLa cells induced by growth factors addition (FBS) and Na,K-ATPase inhibition by ouabain or K<sup>+</sup>-free medium. Values obtained in the absence of stimuli are accepted as 100% (data from Haloui et al. [65]).

been identified in a number of genes (complex promoters consisting of two or more independently functioning parts located upstream of one or several exons and ensuring different size mRNA molecules development from the same gene). For example, alternative promoters for gene *Ppargc1a* encoding coactivator of peroxisome proliferation activator receptor were found in skeletal muscles and nervous tissue. These promoters were located 14 and 587 kb upstream of the canonical promoter, respectively [68, 69]. (iii) 5'-UTR transcription can be regulated by the sequences located in introns or 3'-UTR. All these possibilities have been established for *c-Fos* transcription [70, 71]. In this regard, our laboratory has been screening for genes, whose transcription is altered at initial stages of monovalent ion transmembrane gradient dissipation. We expect that this approach will allow us to identify their common Na<sup>+</sup>-dependent sites (NaRE) and, based on these data, to elucidate the nature of Na<sup>+</sup>-dependent proteins (NaREBs) interacting with these NaREs. (iv) By now, large body of evidence has been accumulated on the regulation of gene expression during gene translocation in the nucleus (so-called three-dimensional transcription regulation model) [72]. Indeed, in the interphase, the

most condensed chromatin part (heterochromatin) is located at the nucleus periphery, while less condensed chromatin (euchromatin) localizes at nucleus center [73]. Transcription factories visualized via incorporation of fluorescently labeled uridine-5'-triphosphate have been mainly observed precisely in the euchromatin [74]. Rearrangement of hetero- and euchromatin is controlled by such epigenetic factors as DNA methylation and acetylation of chromatin. Role of [Na<sup>+</sup>]<sub>i</sub>/[K<sup>+</sup>]<sub>i</sub> ratio increase in the spatial organization regulation of hetero- and euchromatin remains elusive. However, recently reported data indicate that K<sup>+</sup> and Na<sup>+</sup> ions stabilize four-helix guanidine-rich structures (G-quadruplexes) differently. G4-quadruplexes specifically bind mono- and divalent metal ions inside the cavity formed by guanine carbonyl groups. Cations lose their hydrate shells during this process. Maximum stabilization has been observed for K<sup>+</sup>, while Na<sup>+</sup> displays less pronounced stabilizing effect. Interestingly enough, G-quadruplexes are often found in promoters. Further studies will allow to establish whether changes in the stability of G-quadruplexes caused by the increase in the [Na<sup>+</sup>]<sub>i</sub>/[K<sup>+</sup>]<sub>i</sub> ratio are associated with the changes in gene expression [75].

### POTASSIUM AS A TRANSLATIONAL REGULATOR

Fifty years ago, it was found that protein synthesis in prokaryotic cell extracts decreases along with  $K^+$  concentration [76]. Later, this phenomenon has been also observed in animal and plant origin eukaryotic cells (see review by Orlov and Hamet [19]). In this view, it is not surprising that in the vast majority of investigated cell types, including fibroblasts [77], epithelial cells [78], and reticulocytes [79], Na,K-ATPase inhibition is accompanied by protein synthesis reduction without affecting transmembrane transport of labeled amino acids, intracellular ATP content, and ribosome assembly. In case of reticulocyte lysates, half-maximum increase in globin synthesis in media containing 60, 90, and 125 mM  $Na^+$  was observed at  $[K^+] = 15, 25, \text{ and } 40 \text{ mM}$ , respectively [79]. This led to the suggestion that  $Na^+$  (unlike  $K^+$ ) does not activate protein synthesis, but rather competes with  $K^+$  for the sites involved in the translation regulation. Indeed, in contrast to  $K^+$  and  $Rb^+$  ions,  $Na^+$ ,  $Li^+$ , and  $Cs^+$  did not produce any reliably detected effect on the activity of purified human tyrosyl-tRNA synthetase [80].

We must emphasize that observed protein synthesis suppression in intact cells in response to  $[K^+]_i$  decrease can be partially compensated by  $[Na^+]_i$  increase and acti-

vation of previously mentioned  $Na^+$ -dependent mechanism of gene transcription regulation, including those involved in elongation [81, 82]. In particular, we established that Na,K-ATPase inhibition with CTSs in human endothelial cells was accompanied by 3-fold decrease in mRNA content for the translation elongation factor EIF5 [83]. It should also be mentioned that  $K^+$ -dependent translation relative contribution to gene expression regulation is tissue-specific. Indeed, no 24-h ouabain Na,K-ATPase inhibition reliable effect on  $[^3H]$ leucine incorporation into protein fraction of the rat aorta SMCs was observed in the absence of growth factors, which was contrary to 7-8-fold RNA synthesis activation measured by  $[^3H]$ uridine incorporation (Fig. 9). In the presence of growth factors, RNA synthesis increased 10-fold and protein synthesis increased 2-fold. In this case ouabain led to 2-fold protein synthesis decrease while RNA synthesis increased 2-fold [44].

Three hypotheses can be suggested to explain this phenomenon. (i)  $K^+_i$ -dependent sensor content involved in translation regulation is tissue-specific and reduced in SMCs. Indeed, unlike mammalian tyrosyl-tRNA synthetase,  $K^+$  does not affect bacterial enzyme activity [84, 85]. (ii)  $K^+_i$ -sensitive translation regulation mechanism is limited to certain genes [86]. (iii) Gene translation inhibition caused by  $[K^+]_i$  decrease can be compensated by

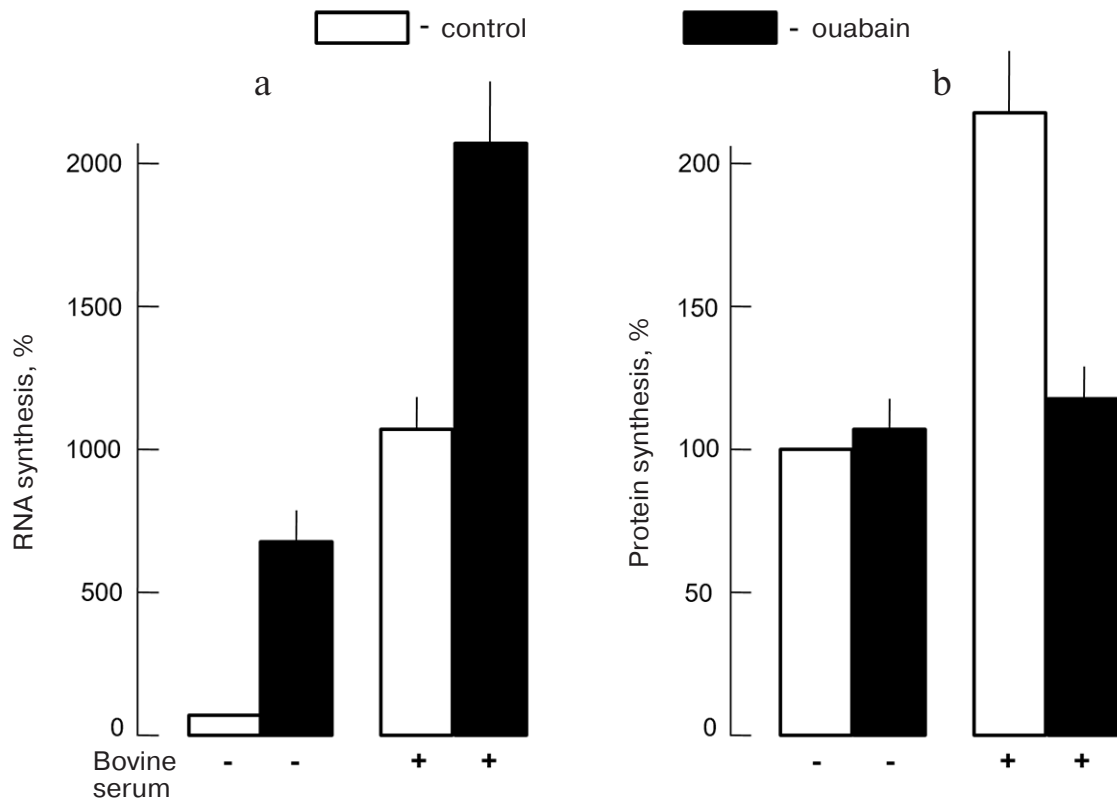

**Fig. 9.** Effect of ouabain (1 mM, 24 h) on RNA (a) and protein (b) synthesis in rat aorta SMCs; CS, 1% bovine serum in the medium (data from Orlov et al. [44]).

above-described mechanism of  $\text{Na}_i^+$ -dependent transcription activation of both studied gene and ERGs involved in the transcription regulation. At present, these hypotheses validation is underway in our laboratory.

#### PHYSIOLOGICAL AND PATHOPHYSIOLOGICAL SIGNIFICANCE OF $\text{Na}_i^+$ , $\text{K}_i^+$ -DEPENDENT GENE EXPRESSION REGULATION MECHANISM

In this section, we will limit ourselves to few examples demonstrating significance of  $\text{Na}_i^+$ ,  $\text{K}_i^+$ -dependent gene expression regulation mechanism and functional cell response generation.

**Myokines secretion.** It was established in early 2000s that skeletal muscles can function as an endocrine organ producing cytokines and other low-molecular-weight proteins (later termed myokines) in response to increasing physical activity. Three mechanisms have been suggested that might explain this phenomenon [57]. (i) Excitation of skeletal muscles is accompanied by L-type  $\text{Ca}^{2+}$  channels activation,  $[\text{Ca}^{2+}]_i$  increase, and gene transcription changes by the mechanisms discussed in the "Proof of  $\text{Ca}^{2+}$ -independent signaling" section. (ii) Physical activity causes increase in AMP/ATP ratio and activation of AMPK involved in gene transcription regulation. (iii) Intense physical activity is accompanied by local decrease in partial oxygen pressure ( $p\text{O}_2$ ), increase in hypoxia-induced factor HIF-1 $\alpha$  synthesis, and activation by HIF-1 $\alpha$ /HIF-1 $\beta$  heterodimer of HREs (HIF-1 response elements) found in 5'-UTR promoters of some  $p\text{O}_2$ -depending genes [18, 87]. In our study, we have obtained evidence for alternative signaling mechanism existence proceeding via transcription activation in response to  $[\text{Na}^+]_i$  increase.

Cultured SMCs subjected to electrical pulse stimulation (EPS) are considered the most adequate contracting skeletal muscle *in vitro* model [88]. We have established that similarly to the *in vivo* experiments [89], 4-h mouse myoblasts C2C12 cells EPS resulted in  $[\text{Na}^+]_i/[\text{K}^+]_i$  5-fold increase [90]. Considering the absence of hypoxia in this type of experiments, we investigated role of  $\text{Ca}^{2+}$ - and AMPK-dependent signaling in C2C12 cells transcriptome change [91]. It was shown that in addition to  $\text{Na}^+$  accumulation and  $\text{K}^+$  loss, EPS was accompanied by rhythmic  $[\text{Ca}^{2+}]_i$  oscillations and changes in 3215 transcripts content. Nicardipine addition (L-type  $\text{Ca}^{2+}$  channel blocker) abolished  $[\text{Ca}^{2+}]_i$  oscillations without affecting  $[\text{Na}^+]_i/[\text{K}^+]_i$  ratio. It was found that EPS-induced alterations in transcription of 1018 genes were maintained in nicardipine presence. Contrary to the changes in ion balance, EPS did not affect acetyl-CoA carboxylase and Unc-51 factor recognized as markers of AMPK activation phosphorylation. Around 300 transcripts, whose content was also altered by the addition of ouabain at concentrations causing  $[\text{Na}^+]_i/[\text{K}^+]_i$  increase correspon-

ding to ones observed in EPS subjected cells, were identified among EPS-dependent genes. Altogether, these data indicate an involvement of  $\text{Na}_i^+$ -dependent,  $\text{Ca}_i^{2+}$ - and AMPK-independent excitation-transcription coupling mechanism in the regulation of gene expression in SMCs.

**Cell memory formation.** Between the 20th and 21st centuries, it was demonstrated that excitation highly increases *Egr1* and *c-Fos* mRNA content in brain neurons [92-94]. Comparison of ouabain and potassium-free medium action on SMCs and cells of electrically non-excitable tissues allowed to classify these genes as  $\text{Na}_i^+$ ,  $\text{K}_i^+$ -dependent ERGs [51, 52]. Ability for learning in *Egr1*<sup>+/-</sup> mice deteriorated sharply [95], which indicated the key role of changes in the neuronal transcriptome mediated by these genes in the development of long-term memory (see review by Thiel et al. [96]). It was established that *Egr1* and other ERGs transcription upregulation induced by neuron excitation was at least partly via activation of *N*-methyl-D-aspartate (NMDA) receptors. Considering that activation of NMDA receptors is accompanied by  $[\text{Ca}^{2+}]_i$  increase, it was suggested that  $\text{Ca}_i^{2+}$ -mediated signaling plays an essential role in long-term memory development [97].

However, NMDA receptors permeability to monovalent cations is higher than to  $\text{Ca}^{2+}$  ( $P_{\text{Na}} \sim P_{\text{K}} \gg P_{\text{Ca}}$ ), and their activation can result in  $[\text{Na}^+]_i/[\text{K}^+]_i$  ratio increase. Indeed,  $[\text{Na}^+]_i$  increase was observed upon both electrical [98] and pharmacological [99] excitation of brain neurons. Using intracellular  $\text{Na}^+$  and  $\text{Ca}^{2+}$  selective fluorescent indicators, it was demonstrated that  $\text{Na}^+$  influx during pyramidal neurons excitation occurs prior to  $[\text{Ca}^{2+}]_i$  increase. It was also established that unlike fast  $[\text{Ca}^{2+}]_i$  normalization,  $[\text{Na}^+]_i$  increase, due to the neuron excitation, returns to normal level within longer period of time [100].

In our latest studies, we investigated ouabain action on  $[\text{Na}^+]_i/[\text{K}^+]_i$  ratio and transcriptome of cultured rat brain neurons [101]. Increase in *Npas4*, *Fos*, *Junb*, *Crem*, *Atf3*, *Klf4*, and *Crebzf* expression was observed among  $[\text{Na}^+]_i/[\text{K}^+]_i$ -dependent transcription regulators. Previously, activation of these ERGs transcription was detected in neurons subjected to electrostimulation or treated with neurotransmitters [93, 94, 102-104]. Participation of these genes in learning and synaptic plasticity has been demonstrated in a number of studies [105, 106]. Currently, we examine the role of  $\text{Ca}_i^{2+}$ -mediated and  $\text{Ca}_i^{2+}$ -independent signaling activated upon dissipation of monovalent cations transmembrane gradients in brain neurons and involved in the alteration of transcriptome in response to electrical and pharmacological stimulation.

**Hypoxia.** As mentioned above, inhibition of HIF-1 degradation in response to  $p\text{O}_2$  decrease and HIF-1 interaction with hypoxia-dependent HREs are considered as certain genes transcriptional regulation main mechanisms in hypoxia. The most studied of these genes are

*Vegfa*, *Edn1*, *Klf10*, and *Nr4a1* [107, 108]. 5'-UTRs of pO<sub>2</sub>-dependent genes, such as *Egr1*, *Atf3*, *Ptgs2*, *Il6*, *Ppp1r5*, *Hes1*, *Nfkbiz*, *Txnip*, *Adamts1*, *Egr3*, *Cxcl2*, and *Hsp70*, do not contain HREs [51]. It has attracted attention that transcription of *Egr1*, *Atf3*, *Ptgs2*, *Il6*, *Ppp1r5*, *Hes1*, *Nfkbiz*, and *Txnip* in SMCs is activated in response to the increase in the [Na<sup>+</sup>]<sub>i</sub>/[K<sup>+</sup>]<sub>i</sub> ratio [51]. In order to investigate the mechanism of this phenomenon, we compared the effects of Na,K-ATPase inhibition and hypoxia in combination with glucose starvation on the SMC transcriptome. Under these conditions, hypoxia resulted in 3-fold [Na<sup>+</sup>]<sub>i</sub> increase and 2-fold [K<sup>+</sup>]<sub>i</sub> increase. Both Na,K-ATPase and hypoxia inhibition caused unidirectional transcription changes in dozens of genes, including *Cyp1a1*, *Fos*, *Atf3*, *Klf10*, *Ptgs2*, *Nr4a1*, *Per2*, and *Hes1*. Elimination of monovalent cations transmembrane gradient using medium with reduced Na<sup>+</sup> content and increased K<sup>+</sup> content abolished ouabain effect on both [Na<sup>+</sup>]<sub>i</sub>/[K<sup>+</sup>]<sub>i</sub> ratio and expression of the above genes. Same procedure also completely prevented hypoxia effect on [Na<sup>+</sup>]<sub>i</sub>/[K<sup>+</sup>]<sub>i</sub> ratio and *Fos*, *Atf3*, *Ptgs2*, and *Per2* transcription and strongly reduced *Klf10*, *Edn1*, *Nr4a1*, and *Hes1* upregulation. SMCs transfection with *Hif-1a* siRNA reduced increase *Vegfa*, *Edn1*, *Klf10*, and *Nr4a1* mRNAs content observed under hypoxia, but did not affect *Fos*, *Atf3*, *Ptgs2*, and *Per2* expression [16, 17]. These results indicate that Na<sup>+</sup>/K<sup>+</sup>-mediated, Hif-1α-independent mechanism of transcription regulation contributes significantly to the regulation of gene expression under hypoxic conditions.

Data presented in this review demonstrate that activity of some enzymes, as well as transcription and translation, are regulated via changes in Na<sup>+</sup> and K<sup>+</sup> intracellular concentrations within physiological range, which allows to consider monovalent cations as secondary messengers. However, it must be emphasized that unlike Ca<sup>2+</sup> and other secondary messengers, molecular structures of Na<sup>+</sup>- and K<sup>+</sup>-binding sites formed by protein tertiary structure have been investigated only for a limited number of sensors (see the section "Identified sensors of monovalent cations"). In addition to these works obvious fundamental significance, continuation of these studies might offer substantial practical applications. For example, it was found that myofibroblasts differentiation activated by tumor transforming growth factor (TGFβ1) was suppressed by CTSs [58]. CTS injections inhibited myofibroblasts accumulation in the lungs of laboratory animals (model of idiopathic pulmonary fibrosis in humans) [109]. It was established that CTSs action is mediated by Na,K-ATPase inhibition, [Na<sup>+</sup>]<sub>i</sub> increase, and following activation of transcription of *Ptgs2* gene encoding COX-2 [58] accompanied by transcription suppression of TGFBR2 subunit of TGFβ1 receptor [58]. It was also shown both in *in vitro* and *in vivo* that CTSs inhibit influenza virus replication through [K<sup>+</sup>]<sub>i</sub> decrease and

suppression of K<sup>+</sup>-dependent translation stages [78]. However, CTSs pharmacological application in doses that increase [Na<sup>+</sup>]<sub>i</sub>/[K<sup>+</sup>]<sub>i</sub> ratio is problematic because of their toxic effect [110]. In this connection, it seems promising to develop drugs that provide tissue-specific effects on the activity of monovalent cation sensors involved in the transcription and translation regulation.

**Funding.** This work was supported by the Russian Science Foundation (project 16-15-10026-p, section "Physiological and pathophysiological significance of Na<sup>+</sup>,K<sup>+</sup>-dependent mechanism of gene expression regulation") and Russian Foundation for Basic Research (project 18-04-00063, sections "Identified sensors of monovalent cations", "Sodium as transcription regulator", and "Potassium as translation regulator").

**Acknowledgements.** The authors express their gratitude to Prof. A. A. Mongin (Albany Medical College, USA) for reading this review and providing critical comments.

**Conflict of interest.** The authors declare no conflict of interest in financial or any other sphere.

**Ethical approval.** All applicable international, national, and/or institutional guidelines for the care and use of animals were followed.

## REFERENCES

1. Sutherland, E. W. (1972) Studies on the mechanism of hormone action, *Science*, **177**, 401-408.
2. Robison, G. A., Butcher, R. W., and Sutherland, E. W. (1971) *Cyclic AMP*, Academic Press, New York.
3. Lincoln, T. M., and Cornwell, T. L. (1993) Intracellular cyclic GMP receptor proteins, *FASEB J.*, **7**, 328-338.
4. Carafoli, E. (2002) Calcium signaling: a tale for all seasons, *Proc. Natl. Acad. Sci. USA*, **99**, 1115-1122.
5. Berridge, M. J. (1993) Inositol triphosphate and calcium signalling, *Nature*, **361**, 315-325.
6. Grinstein, S., Smith, J. D., Benedict, S. H., and Gelfand, E. W. (1989) Activation of sodium-hydrogen exchange by mitogens, *Curr. Topics Membr. Transport*, **34**, 331-343.
7. Prasad, K. V. S., Severini, A., and Kaplan, J. G. (1987) Sodium ion fluxes in proliferating lymphocytes: an early component of mitogenic signal, *Arch. Biochem. Biophys.*, **252**, 515-525.
8. Wakabayashi, S., Shigekawa, M., and Poyssegur, J. (1997) Molecular physiology of vertebrate Na<sup>+</sup>/H<sup>+</sup> exchanger, *Physiol. Rev.*, **77**, 51-74.
9. Marakhova, I. I., Vereninov, A. A., Toropova, F. V., and Vinogradova, T. A. (1998) Na,K-ATPase pump in activated human lymphocytes: on the mechanisms of rapid and long-term increase in K influxes during the initiation of phytohemagglutinin-induced proliferation, *Biochim. Biophys. Acta*, **1368**, 61-72.
10. Burns, C. P., and Rozengurt, E. (1984) Extracellular Na<sup>+</sup> and initiation of DNA synthesis: role of intracellular pH and K<sup>+</sup>, *J. Cell Biol.*, **98**, 1082-1089.

11. Hamet, P., Orlov, S. N., DeBlois, D., Sun, Y., Kren, V., and Tremblay, J. (2004) *Angiotensin As a Cytokine Implicated in Accelerated Cellular Turnover*, Springer Verlag, N. Y., pp. 71-98.
12. Bennekou, P., and Christophersen, P. (2003) *Ion Channels*, Springer, Berlin, pp. 139-152.
13. Schneider, J., Nicolay, J. P., Foller, M., Wieder, T., and Lang, F. (2007) Suicidal erythrocyte death following cellular  $K^+$  loss, *Cell Physiol. Biochem.*, **20**, 35-44.
14. Rose, C. R., and Konnerth, A. (2001) NMDA-receptor-mediated  $Na^+$  signals in spines and dendrites, *J. Neurosci.*, **21**, 4207-4214.
15. Verkhatsky, A., Noda, M., Parpura, V., and Kirischuk, S. (2013) Sodium fluxes and astroglial function, *Adv. Exp. Med. Biol.*, **961**, 295-305.
16. Koltsova, S. V., Shilov, B., Burulina, J. G., Akimova, O. A., Haloui, M., Kapilevich, L. V., Gusakova, S. V., Tremblay, J., Hamet, P., and Orlov, S. N. (2014) Transcriptomic changes triggered by hypoxia: evidence for HIF-1 $\alpha$  -independent,  $[Na^+]_i/[K^+]_i$ -mediated excitation-transcription coupling, *PLoS One*, **9**, e110597.
17. Orlov, S. N., Birulina, Y. G., Smaglii, L. V., and Gusakova, S. V. (2017) Vascular smooth muscle as an oxygen sensor: role of elevation of the  $[Na^+]_i/[K^+]_i$ , in *Hypoxia and Human Diseases* (Zheng, J., and Zhou, C., eds.) IntechOpen, Vol. 4, pp. 73-90; doi: 10.5772/65384.
18. Kapilevich, L. V., Kironenko, T. A., Zaharova, A. N., Kotelevtsev, Yu., Dulin, N. O., and Orlov, S. N. (2015) Skeletal muscle as an endocrine organ: role of  $[Na^+]_i/[K^+]_i$ -mediated excitation-transcription coupling, *Genes Dis.*, **2**, 328-336.
19. Orlov, S. N., and Hamet, P. (2006) Intracellular monovalent ions as second messengers, *J. Membr. Biol.*, **210**, 161-172.
20. Shekarabi, M., Zhang, J., Khanna, A. R., Ellison, D. H., Delpire, E., and Kahle, K. T. (2017) WNK kinase signaling in ion homeostasis and human disease, *Cell Metab.*, **25**, 285-299.
21. Wilson, C. S., and Mongin, A. A. (2019) The signaling role for chloride in the bidirectional communication between neurons and astrocytes, *Neurosci. Lett.*, **689**, 33-44.
22. Page, M. J., and Di Cera, E. (2006) Role of  $Na^+$  and  $K^+$  in enzyme function, *Physiol. Rev.*, **86**, 1049-1092.
23. Linden, D. J., Smeyne, M., and Connor, J. A. (1993) Induction of cerebellar long-term depression in culture requires postsynaptic action of sodium ions, *Neuron*, **11**, 1093-1100.
24. Kanai, R., Ogawa, H., Vilsen, B., Cornelius, F., and Toyoshima, C. (2013) Crystal structure of  $Na^+$ -bound  $Na^+,K^+$ -ATPase preceding the E1P state, *Nature*, **502**, 201-206.
25. Sweadner, K. J., and Donnet, C. (2001) Structural similarities of  $Na,K$ -ATPase and SERCA, the  $Ca^{2+}$ -ATPase of the sarcoplasmic reticulum, *Biochem. J.*, **356**, 685-704; doi: 10.1042/0264-6021:3560685.
26. Toyoshima, C., Kanai, R., and Cornelius, F. (2011) First crystal structure of  $Na^+,K^+$ -ATPase: new light on the oldest ion pump, *Structure*, **19**, 1732-1738; doi: 10.1016/j.str.2011.10.016.
27. Pert, C. B., Pasternak, G., and Snyder, S. H. (1973) Opiate agonists and antagonists discriminated by receptor binding in brain, *Science*, **182**, 1359-1361.
28. Katritch, V., Fenalti, G., Abola, E. E., Roth, B. L., Cherezov, V., and Stevens, R. C. (2014) Allosteric sodium in class A GPCR signaling, *Trends Biochem. Sci.*, **39**, 233-244.
29. Strasser, A., Wittmann, H.-J., Schneider, E. H., and Seifert, R. (2015) Modulation of GPCRs by mivalent cations and anions, *Naunyn Schmied. Arch. Pharmacol.*, **388**, 363-380; doi: 10.1007/s00210-014-1073-2.
30. Liu, W., Chun, E., Thompson, A. A., Chubukov, P., Xu, F., Katritch, V., Han, G. W., Roth, C. B., Heitman, L. H., Ijzerman, A. P., Cherezov, V., and Stevens, R. C. (2012) Structural basis for allosteric regulation of GPCRs by sodium ions, *Science*, **337**, 232-236.
31. Fenalti, G., Giguere, P. M., Katritch, V., Huang, X. P., Thompson, A. A., Cherezov, V., Roth, B. L., and Stevens, R. C. (2014) Molecular control of d-opioid receptor signalling, *Nature*, **506**, 191-196.
32. Gutierrez-de-Teran, H., Massink, A., Rodriguez, D., Liu, W., Han, G. W., Joseph, J. S., Katritch, I., Heitman, L. H., Xia, L., Ijzerman, A. P., Cherezov, V., Katritch, V., and Stevens, R. C. (2013) The role of sodium ion-binding site in the allosteric modulation of the A2A adenosine G protein-coupled receptor, *Structure*, **21**, 2175-2185.
33. O'Brien, M.-C., and McKay, D. B. (1995) How potassium affects the activity of the molecular chaperone Hsc70. I. Potassium is required for optimal ATPase activity, *J. Biol. Chem.*, **270**, 2247-2250.
34. Arakawa, A., Handa, N., Shirouzu, M., and Yokoyama, S. (2011) Biochemical and structural studies on the high affinity of Hsp70 for ADP, *Protein Sci.*, **20**, 1367-1379.
35. Orlov, S. N. (1987) *Clamodulin: General Problems of Physicochemical Biology* [in Russian], VINITI, Moscow, Vol. 8, pp. 5-212.
36. Permyakov, E. A., Uversky, V. N., and Permyakov, S. E. (2017) Parvalbumin as a pleomorphic protein, *Curr. Protein Pept. Sci.*, **18**, 780-794.
37. Heizmann, C. W., and Hunziker, W. (1991) Intracellular calcium-binding proteins: more sites than insights, *Trends Biochem. Sci.*, **16**, 98-103.
38. Okada, Y., Maeno, E., Shimizu, T., Dezaki, K., Wang, J., and Morishima, S. (2001) Receptor-mediated control of regulatory volume decrease (RVD) and apoptotic volume decrease (AVD), *J. Physiol.*, **532**, 3-16.
39. Orlov, S. N., Platonova, A. A., Hamet, P., and Grygorczyk, R. (2013) Cell volume and monovalent ion transporters: their role in the triggering and progression of the cell death machinery, *Am. J. Physiol. Cell Physiol.*, **305**, C361-C372.
40. Orlov, S. N., Thorin-Trescases, N., Kotelevtsev, S. V., Tremblay, J., and Hamet, P. (1999) Inversion of the intracellular  $Na^+/K^+$  ratio blocks apoptosis in vascular smooth muscle at a site upstream of caspase-3, *J. Biol. Chem.*, **274**, 16545-16552.
41. Zhou, X., Jiang, G., Zhao, A., Bondeva, T., Hirzel, P., and Balla, T. (2001) Inhibition of  $Na,K$ -ATPase activates PI3 kinase and inhibits apoptosis in LLC-PK1 cells, *Biochem. Biophys. Res. Commun.*, **285**, 46-51.
42. Isaev, N. K., Stelmashook, E. V., Halle, A., Harms, C., Lautenschlager, M., Weih, M., Dirnagl, U., Victorov, I. V., and Zorov, D. B. (2000) Inhibition of  $Na^+,K^+$ -ATPase activity in cultured cerebellar granule cells prevents the onset of apoptosis induced by low potassium, *Neurosci. Lett.*, **283**, 41-44.

43. Trevisi, L., Visentin, B., Cusinato, F., Pighin, I., and Luciani, S. (2004) Antiapoptotic effect of ouabain on human umbilical endothelial cells, *Biochem. Biophys. Res. Commun.*, **321**, 716-721.
44. Orlov, S. N., Taurin, S., Tremblay, J., and Hamet, P. (2001) Inhibition of Na<sup>+</sup>,K<sup>+</sup> pump affects nucleic acid synthesis and smooth muscle cell proliferation via elevation of the [Na<sup>+</sup>]<sub>i</sub>/[K<sup>+</sup>]<sub>i</sub> ratio: possible implication in vascular remodeling, *J. Hypertens.*, **19**, 1559-1565.
45. Taurin, S., Seyrantepe, V., Orlov, S. N., Tremblay, T.-L., Thibaut, P., Bennett, M. R., Hamet, P., and Pshezhetsky, A. V. (2002) Proteome analysis and functional expression identify mortalin as an anti-apoptotic gene induced by elevation of [Na<sup>+</sup>]<sub>i</sub>/[K<sup>+</sup>]<sub>i</sub> ratio in cultured vascular smooth muscle cells, *Circ. Res.*, **91**, 915-922.
46. Orlov, S. N., and Hamet, P. (2004) Apoptosis vs oncosis: role of cell volume and intracellular monovalent cations, *Adv. Exp. Med. Biol.*, **559**, 219-233.
47. Taurin, S., Dulin, N. O., Pchejetski, D., Grygorczyk, R., Tremblay, J., Hamet, P., and Orlov, S. N. (2002) c-Fos expression in ouabain-treated vascular smooth muscle cells from rat aorta: evidence for an intracellular-sodium-mediated, calcium-independent mechanism, *J. Physiol.*, **543**, 835-847.
48. Orlov, S. N., Taurin, S., Thorin-Trescases, N., Dulin, N. O., Tremblay, J., and Hamet, P. (2000) Inversion of the intracellular Na<sup>+</sup>/K<sup>+</sup> ratio blocks apoptosis in vascular smooth muscle cells by induction of RNA synthesis, *Hypertension*, **35**, 1062-1068.
49. Schoner, W., and Scheiner-Bobis, G. (2007) Endogenous and exogenous cardiac glycosides: their role in hypertension, salt metabolism, and cell growth, *Am. J. Physiol. Cell Physiol.*, **293**, C509-C536.
50. Orlov, S. N., Klimanova, E. A., Tverskoi, A. M., Vladychenskaya, E. A., Smolyaninova, L. V., and Lopina, O. D. (2017) Na<sup>+</sup>,K<sup>+</sup>-dependent and -independent signaling triggered by cardiotoxic steroids: facts and artifacts, *Molecules*, **22**, E635; doi: 10.3390/molecules22040635.
51. Koltsova, S. V., Trushina, Y., Haloui, M., Akimova, O. A., Tremblay, J., Hamet, P., and Orlov, S. N. (2012) Ubiquitous [Na<sup>+</sup>]<sub>i</sub>/[K<sup>+</sup>]<sub>i</sub>-sensitive transcriptome in mammalian cells: evidence for Ca<sup>2+</sup>-independent excitation-transcription coupling, *PLoS One*, **7**, e38032.
52. Klimanova, E. A., Sidorenko, S. V., Smolyaninova, L. V., Kapilevich, L. V., Gusakova, S. V., Lopina, O. D., and Orlov, S. N. (2019) Ubiquitous and cell type-specific transcriptomic changes triggered by dissipation of monovalent cation gradients in rodent cells: physiological and pathophysiological implications, *Curr. Top. Membr.*, **83**, 107-149; doi: 10.1016/bs.ctm.2019.01.006.
53. Orlov, S. N., Thorin-Trescases, N., Pchejetski, D., Taurin, S., Farhat, N., Tremblay, J., Thorin, E., and Hamet, P. (2004) Na<sup>+</sup>/K<sup>+</sup> pump and endothelial cell survival: [Na<sup>+</sup>]<sub>i</sub>/[K<sup>+</sup>]<sub>i</sub>-independent necrosis triggered by ouabain, and protection against apoptosis mediated by elevation of [Na<sup>+</sup>]<sub>i</sub>, *Pflugers Arch.*, **448**, 335-345.
54. Alonso, M. T., and Garcia-Sancho, J. (2011) Nuclear Ca<sup>2+</sup> signalling, *Cell Calcium*, **49**, 280-289.
55. Taurin, S., Hamet, P., and Orlov, S. N. (2003) Na/K pump and intracellular monovalent cations: novel mechanism of excitation-transcription coupling involved in inhibition of apoptosis, *Mol. Biol.*, **37**, 371-381.
56. Santana, L. F. (2008) NFAT-dependent excitation-transcription coupling in heart, *Circ. Res.*, **103**, 681-683.
57. Gundersen, K. (2011) Excitation-transcription coupling in skeletal muscle: the molecular pathways of exercise, *Biol. Rev.*, **86**, 564-600.
58. La, J., Reed, E. B., Koltsova, S. V., Akimova, O. A., Hamanaka, R. B., Mutlu, R. B., Orlov, S. N., and Dulin, N. O. (2016) Regulation of myofibroblast differentiation by cardiac glycosides, *Am. J. Physiol. Lung Cell. Mol. Physiol.*, **310**, L815-L823.
59. Smolyaninova, L. V., Koltsova, S. V., Sidorenko, S. V., and Orlov, S. N. (2017) Augmented gene expression triggered by Na<sup>+</sup>,K<sup>+</sup>-ATPase inhibition: role of Ca<sup>2+</sup>-mediated and -independent excitation-transcription coupling, *Cell Calcium*, **68**, 5-13.
60. Orlov, S. N., Aksentsev, S. L., and Kotelevtsev, S. V. (2005) Extracellular calcium is required for the maintenance of plasma membrane integrity in nucleated cells, *Cell Calcium*, **38**, 53-57.
61. Koltsova, S. V., Tremblay, J., Hamet, P., and Orlov, S. N. (2015) Transcriptomic changes in Ca<sup>2+</sup>-depleted cells: role of elevated intracellular [Na<sup>+</sup>]/[K<sup>+</sup>] ratio, *Cell Calcium*, **58**, 317-324.
62. Matt, T., Martinez-Yamout, M. A., Dyson, H. J., and Wright, P. E. (2004) The CBP/p300 XAZ1 domain in its native state is not a binding partner of MDM2, *Biochem. J.*, **381**, 685-691.
63. Krishtal, O. A., Pidoplichko, V. I., and Shakhvalov, Y. A. (1981) Conductance of the calcium channel in the membrane of snail neurones, *J. Physiol.*, **301**, 423-434.
64. Nakagawa, Y., Rivera, V., and Larner, A. C. (1992) A role for Na/K-ATPase in the control of human c-fos and c-jun transcription, *J. Biol. Chem.*, **267**, 8785-8788.
65. Haloui, M., Taurin, S., Akimova, O. A., Guo, D.-F., Tremblay, J., Dulin, N. O., Hamet, P., and Orlov, S. N. (2007) Na<sup>+</sup>-induced c-Fos expression is not mediated by activation of the 5'-promoter containing known transcriptional elements, *FEBS J.*, **274**, 3257-3267.
66. Ono, Y., Ojimam, K., Torii, F., Takaya, E., Doi, N., Nakagawa, K., Hata, S., Abe, K., and Sorimachi, H. (2010) Skeletal muscle-specific calpain is an intracellular Na<sup>+</sup>-dependent protease, *J. Biol. Chem.*, **285**, 22986-22998.
67. Herrera, R. E., Nordheim, A., and Stewart, A. F. (1997) Chromatin structure analysis of the human c-Fos promoter reveals a centrally positioned nucleosome, *Chromosoma*, **106**, 284-292.
68. Chinsomboon, J., Ruas, J., Gupta, R. K., Thom, R., Shoag, J., Rowe, G. C., Sawada, N., Raghuram, S., and Arany, Z. (2009) The transcriptional coactivator PGC-1alpha mediates exercise-induced angiogenesis in skeletal muscle, *Proc. Natl. Acad. Sci. USA*, **106**, 21401-21405.
69. Soyol, S. M., Felder, T. K., Auer, S., Hahne, P., Oberkofler, H., Witting, A., Paulmichl, M., Landwehrmeyer, G. B., Weydt, P., and Patsch, W. (2012) A greatly extended PPARGC1A genomic locus encodes several new brain-specific isoforms and influences Huntington disease age of onset, *Hum. Mol. Genet.*, **21**, 3461-3470.
70. Mechti, N., Piechaczyk, M., Blanchard, J. M., Jeanteur, P., and Lebleu, B. (1991) Sequence requirements for premature transcription arrest within the first intron of the mouse c-fos gene, *Mol. Cell. Biol.*, **11**, 2832-2841.

71. Coulon, V., Veyrune, J.-L., Tourkine, N., Vie, A., Hipskind, R. A., and Blanchard, J.-M. (1999) A novel calcium signaling pathway targets the *c-fos* intragenic transcriptional pausing site, *J. Biol. Chem.*, **274**, 30439-30446.
72. Lanctot, C., Cheutin, T., Cremer, M., Cavalli, G., and Cremer, T. (2007) Dynamic genome architecture in the nuclear space: regulation of gene expression in three dimensions, *Nature Rev. Genet.*, **8**, 104-115.
73. Trinkle-Mulchany, L., and Lamond, A. I. (2008) Nuclear functions in space and time: gene expression in a dynamic, constrained environment, *FEBS Lett.*, **582**, 1960-1970.
74. Maharana, S., Sharma, D., Shi, X., and Shivashankar, G. V. (2012) Dynamic organization of transcription compartments is dependent in functional nuclear architecture, *Biophys. J.*, **103**, 851-859.
75. Dolinnaya, N. G., Ogloblina, A. M., and Yakubovskaya, M. G. (2016) Structure, properties, and biological relevance of the DNA and RNA G-quadruplexes: overview 50 years after their discovery, *Biochemistry (Moscow)*, **81**, 1602-1649.
76. Lubin, M., and Ennis, H. L. (1964) On the role of intracellular potassium in protein synthesis, *Biochim. Biophys. Acta*, **80**, 614-631.
77. Ledbetter, M. L. S., and Lubin, M. (1977) Control of protein synthesis in human fibroblasts by intracellular potassium, *Exp. Cell Res.*, **105**, 223-236.
78. Amarelle, L., Katzen, J., Shigemura, M., Welch, L. C., Cajigas, H., Peteranderl, C., Celli, D., Herold, S., Lecuona, E., and Sznajder, J. L. (2019) Cardiac glycosides decrease influenza virus replication by inhibiting cell protein translation machinery, *Am. J. Physiol. Lung Cell. Mol. Physiol.*, **316**, L1094-L1106; doi: 10.1152/ajplung.00173.2018.
79. Cahn, F., and Lubin, M. (1978) Inhibition of elongation steps of protein synthesis at reduced potassium concentrations in reticulocytes and reticulocyte lysate, *J. Biol. Chem.*, **253**, 7798-7803.
80. Austin, J., and First, E. A. (2002) Potassium functionally replaced the second lysine of the KMSKS signature sequence in human tyrosyl-tRNA synthetase, *J. Biol. Chem.*, **277**, 20243-20248.
81. Jennings, M. D., and Pavitt, G. D. (2010) eIF5 is a dual function GAP and GDI for eukaryotic translational control, *Small GTPases*, **1**, 118-123.
82. Cao, J., He, L., Lin, G., Hu, C., Dong, R., Zhang, J., Zhu, H., Hu, Y., Wagner, C. R., He, Q., and Yang, B. (2014) Cap-dependent translation initiation factor, eIF4E, is the target for ouabain-mediated inhibition of HIF-1 $\alpha$ , *Biochem. Pharmacol.*, **89**, 20-30.
83. Klimanova, E. A., Tverskoi, A. M., Koltsova, S. V., Sidorenko, S. V., Lopina, O. D., Tremblay, J., Hamet, P., Kapilevich, L. V., and Orlov, S. N. (2017) Time- and dose-dependent actions of cardiotonic steroids on transcriptome and intracellular content of Na<sup>+</sup> and K<sup>+</sup>: a comparative analysis, *Sci. Rep.*, **7**, 45403; doi: 10.1038/srep45403.
84. Fisher, P. A., Goodman, J. G., and Kull, F. L. (1976) Thyroid ribonucleic acid-iodopeptides. Comparison of tyrosyl-complex II and tyrosyl-tRNA, *Biochemistry*, **15**, 4065-4070.
85. Quivy, J. P., and Chroboczek, J. (1988) Tyrypsyl-tRNA synthetase from wheat germ, *J. Biol. Chem.*, **263**, 15277-15281.
86. Dever, T. E. (2002) Gene-specific regulation by general translation factors, *Cell*, **108**, 545-556.
87. Pedersen, B. K., and Febbraio, M. A. (2008) Muscle as an endocrine organ: focus on muscle-derived interleukin-6, *Physiol. Rev.*, **88**, 1379-1406.
88. Nikolic, N., Gordens, S. W., Thoresen, G. H., Aas, V., Eckel, J., and Eckardt, K. (2017) Electrical pulse stimulation of cultured skeletal muscle cells as a model for *in vitro* exercise – possibilities and limitations, *Acta Physiol.*, **220**, 310-331.
89. Murphy, K. T., Nielsen, O. B., and Clausen, T. (2008) Analysis of exercise-induced Na<sup>+</sup>-K<sup>+</sup> exchange in rat skeletal muscle, *Exp. Physiol.*, **93**, 1249-1262.
90. Danilov, K., Sidorenko, S. V., Milovanova, K., Klimanova, E. A., Kapilevich, L. V., and Orlov, S. N. (2017) Electrical pulse stimulation decreases electrochemical Na<sup>+</sup> and K<sup>+</sup> gradients in C2C12 myotubes, *Biochem. Biophys. Res. Commun.*, **493**, 875-878.
91. Sidorenko, S. V., Klimanova, E. A., Milovanova, K., Lopina, O. D., Kapilevich, L. V., Chibalin, A. V., and Orlov, S. N. (2018) Transcriptomic changes in C2C12 myotubes triggered by electrical stimulation: role of Ca<sub>i</sub><sup>2+</sup>-mediated and Ca<sub>i</sub><sup>2+</sup>-independent signaling and elevated [Na<sub>i</sub><sup>+</sup>]/[K<sub>i</sub><sup>+</sup>] ratio, *Cell Calcium*, **76**, 72-86.
92. Bakowski, D., and Parekh, A. B. (2002) Monovalent cation permeability and Ca<sup>2+</sup> block of the store-operated Ca<sup>2+</sup> current ICRAC in rat basophilic leukemia cells, *Pflugers Arch. Eur. J. Physiol.*, **443**, 892-902.
93. Hunt, S. P., Pini, A., and Evan, G. (1987) Induction of c-Fos-like protein in spinal cord neurons following sensory stimulation, *Nature*, **328**, 632-634.
94. Cole, A. J., Saffen, D. W., Baraban, J. M., and Worley, P. F. (1989) Rapid increase of an immediate early gene messenger RNA in hippocampal neurons by synaptic NMDA receptor activation, *Nature*, **340**, 474-476.
95. Jones, M. W., Errington, M. L., French, P. J., Fine, P. J., Bliss, T. V. P., Garel, S., Charney, P., Bozon, B., Laroche, S., and Davis, S. (2001) A requirement for the immediate early response gene Zif268 in the expression of late LTP and long-term memories, *Nat. Neurosci.*, **4**, 289-296.
96. Thiel, G., Mayer, S. I., Muller, I., Stefano, L., and Rossler, O. G. (2010) Egr-1 – a Ca<sup>2+</sup>-regulated transcription factor, *Cell Calcium*, **47**, 397-403.
97. Alberini, C. A. (2009) Transcription factors in long-term memory and synaptic plasticity, *Physiol. Rev.*, **89**, 121-145.
98. Bennay, M., Langer, J., Meier, S. D., Kafitz, K. W., and Rose, C. R. (2008) Sodium signals in cerebellar Purkinje neurons and bergmann glial cells evoked by glutamatergic synaptic transmission, *Glia*, **56**, 1138-1149.
99. Jaffe, D. B., Johnston, D., Lasser-Ross, N., Lisman, J. E., Miyakawa, H., and Ross, W. N. (1992) The spread of Na<sup>+</sup> spikes determines the pattern of dendritic Ca<sup>2+</sup> entry into hippocampal neurones, *Nature*, **357**, 244-246.
100. Baeza-Lehnert, F., Saab, A. S., Gutierrez, R., Larenas, V., Diaz, E., Horn, M., Vargas, M., Hosli, L., Stobart, J., Hirrlinger, J., Weber, B., and Barros, L. F. (2019) Non-canonical control of neuronal energy status by the Na<sup>+</sup> pump, *Cell Metab.*, **29**, 1-13.
101. Smolyaninova, L. V., Shiyana, A. A., Kapilevich, L. V., Lopachev, A. V., Fedorova, T. N., Klementieva, T. S., Moskovtsev, A. A., Kubatiev, A. A., and Orlov, S. N. (2019) Transcriptomic changes triggered by ouabain in rat cere-

- bellum granule cells: role of  $\alpha 3$ - and  $\alpha 1$ -mediated signaling, *PLoS One*, in press.
102. Coba, M. P., Valor, L. M., Kopanitsa, M. V., Afinowi, N. O., and Grant, S. G. (2008) Kinase networks integrate profiles of N-methyl-D-aspartate receptor-mediated gene expression in hippocampus, *J. Biol. Chem.*, **283**, 34101-34107.
  103. Barry, D. N., and Commins, S. (2017) Temporal dynamics of immediate early gene expression during cellular consolidation of spatial memory, *Behav. Brain Res.*, **327**, 44-53.
  104. Zhu, S., Tai, C., MacVicar, B. A., Jia, W., and Cynader, M. S. (2009) Glutamatergic stimulation triggers rapid Kruppel-like factor 4 expression in neurons and the over-expression of KLF4 sensitizes neurons to NMDA-induced caspase-3 activity, *Brain Res.*, **1250**, 49-62.
  105. Flavell, S. W., and Greenberg, M. E. (2008) Signaling mechanisms linking neuronal activity to gene expression and plasticity of the nervous system, *Annu. Rev. Neurosci.*, **31**, 563-590.
  106. Malik, A. N., Vierbuchen, T., Hemberg, M., Rubin, A. A., Ling, E., Couch, C. H., Stroud, H., Spiegel, I., Kai-How Farth, K., Harmin, D. A., and Greenberg, M. E. (2014) Genome-wide identification and characterization of functional activity-dependent enhancers, *Nat. Neurosci.*, **17**, 1330-1339.
  107. Semenza, G. L. (2003) Targeting HIF-1 for cancer therapy, *Nat. Rev. Cancer*, **3**, 721-732.
  108. Wood, I. S., Perez de Heredia, F., Wang, B., and Trayhurn, P. (2009) Cellular hypoxia and adipose tissue dysfunction in obesity, *Proc. Nutr. Soc.*, **68**, 370-377; doi: 10.1017/S0029665109990206.
  109. Orlov, S. N., La, J., Smolyaninova, L. V., and Dulin, N. O. (2019)  $\text{Na}^+, \text{K}^+$ -ATPase as a target for treatment of tissue fibrosis, *Curr. Med. Chem.*, **26**, 564-575; doi: 10.2174/0929867324666170619105407.
  110. Akimova, O. A., Tverskoi, A. M., Smolyaninova, L. V., Mongin, A. A., Lopina, O. D., La, J., Dulin, N. O., and Orlov, S. N. (2015) Critical role of the  $\alpha 1$ - $\text{Na}^+, \text{K}^+$ -ATPase subunit in insensitivity of rodent cells to cytotoxic action of ouabain, *Apoptosis*, **20**, 1200-1210.